

Call for Tender

Summary of Technical Specification for the Low Voltage Insulation Breaks for the ITER Magnets

Table of Contents

1	PURPOSE	1
2	SCOPE	1
3	DEFINITIONS	2
4	DESCRIPTION OF THE LVIBS	2
5	TENTATIVE SCHEDULE	3
6	EXPERIENCE REQUIREMENTS	3
7	CANDIDATURE	3

1 Purpose

This document provides a summary of the technical requirements for the Low Voltage Insulation Breaks (LVIBs) to be used in the ITER magnet system. These components will be procured by the ITER Organisation via a call for tender.

2 Scope

The LVIB Contract will be structured in two Phases. In Phase 1, the Contractor will design and manufacture 20 (twenty) prototype LVIBs, and demonstrate that they meet the technical requirements by performing a qualification programme on them. In the event that the prototype LVIBs fulfil all the technical requirements, the Contractor will proceed to Phase 2 of the Contract, which is the manufacture of a total of 190 LVIBs for use in the ITER machine. These 190 LVIBs will undergo a QA/QC procedure to ensure that they meet the requirements for use in the ITER machine.

3 Definitions

LVIB – Low Voltage Insulation Break

Contractor – the company/ institute executing this Contract.

IO – ITER Organization

QA/QC – Quality Assurance/Quality Control

4 Description of the LVIBs

The LVIBs which the Contractor will deliver to the ITER Organisation will be installed within the structure cooling feeders of the ITER machine. The structure cooling feeders are responsible for conveying supercritical helium at a temperature of approximately 4 K to cool the stainless steel cases of the Toroidal Field magnets (and other magnet structural support systems). The structure cooling feeders consist of a parallel network of steel pipes which distribute the supercritical helium to all the Toroidal Field magnets. LVIBs will be welded into the pipework of all the branches of the network. The purpose of the LVIBs is to suppress the circulation of eddy currents within the pipework of the structure cooling feeders which could be deleterious to the conditions required for good operation of the ITER machine. The image below shows part of the pipework of the structure cooling feeders, and the LVIBs are represented by the green cylinders.

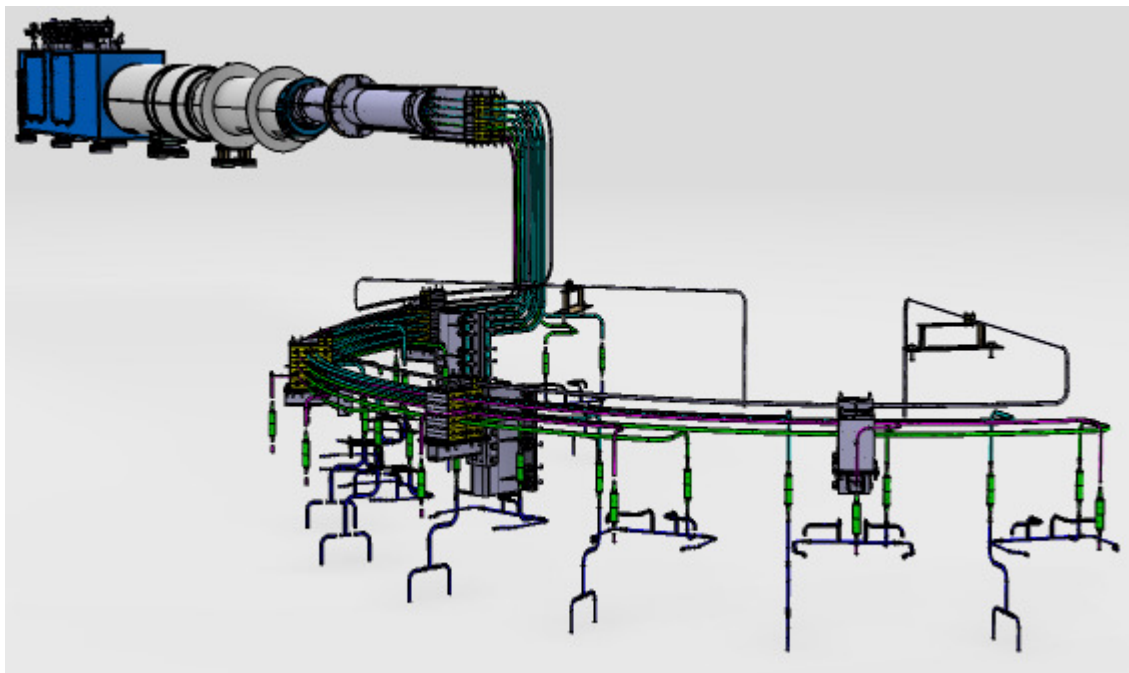

The LVIBs will operate at cryogenic temperatures. They will carry supercritical helium internally, whilst externally they will be located within a vacuum. A critical requirement is that they remain helium leak-tight, and they must be designed to be completely maintenance-free for the operational life of the ITER machine of 20 years. Other key requirements on the LVIBs are listed below:

- The LVIBs must be able to sustain a total radiation dose of 200 kGy.

- The LVIBs must be able to sustain large mechanical loads, including bending.
- The LVIBs must provide voltage isolation to 1 kV

In order to meet these requirements, the LVIBs will consist of a composite tube bonded at both ends to stainless steel pipes. This assembly will then be over-wrapped with glass fibre impregnated in resin.

5 Tentative Schedule

Activity	Schedule
Invitation for Call for Tender	July 2017
Tender Submission	September 2017
Contract Signature	December 2017
Completion of LVIB design	March 2018
Completion of LVIB Qualification	September 2018
Completion of series delivery of LVIBs to IO	December 2019

6 Experience Requirements

The ITER Organization is looking for Contractors with the following experience:

- Experience in the design of composite parts for use at cryogenic temperatures;
- Experience in the manufacture of composite parts, in particular filament winding techniques;
- Experience in leak testing assemblies;
- QA/QC procedures applied to composite component manufacture and test.

7 Candidature

Candidature is open to all companies participating either individually or in a grouping (consortium) which is established in an ITER Member State. A consortium may be a permanent, legally-established grouping, or a grouping which has been constituted informally for a specific tender procedure. All members of a consortium (i.e. the leader and all other members) are jointly and severally liable to the ITER Organization.

The consortium groupings shall be presented at the tender submission stage. The consortium cannot be modified later without the approval of the ITER Organization.